



# Owner's Manual





## An Introduction

Thank you for purchasing a JL Audio W7 subwoofer driver. The W7 embodies JL Audio's commitment to pushing the envelope of speaker technology, with eight patented technologies, a design patent and a completely unique set of component parts. Each W7 model has been meticulously engineered to reproduce sub-bass with extreme fidelity at any volume level, provided it is installed and tuned properly. Please review the information in this document carefully so as to maximize your enjoyment of the W7's capabilities.

Two enclosure recommendations are listed for each model, one sealed and one ported. The sealed enclosure design will, in most cases, give you the best overall sound quality and take up the least space in your vehicle. The ported enclosure design will deliver additional output over the sealed enclosure (about 3 - 4 dB more) and will also maintain excellent sound quality, but it will require significantly more space to install. The recommended ported enclosure is not designed for peaky "competition SPL" performance, it is designed for music listening. It will be very loud and sound extremely good when set up properly.

In addition to the enclosure recommendations, we also provide recommended amplifier settings for JL Audio amplifiers used with W7's. Some of this information is also applicable with other brands of amplifiers (like crossover points and slopes), some is not (like the voltage levels specified for input sensitivity settings). You will notice that our recommended settings do not include any bass EQ boost... this is because W7's rarely require any equalization to produce smooth frequency response. If you have an equalizer in your system (or one is included in your head unit or amplifier), defeat all bands below 125 Hz before dialing in your new system settings. Please turn off all sound processing that would affect the subwoofers (loudness circuits for example).

**For optimum sub-bass performance, the amplifier input sensitivity must be adjusted to avoid excessive distortion (clipping) of the amplifier output.** With W7 subwoofers, a clipped amplifier output will manifest itself audibly as a low-level "mechanical" sound coming from the speakers. Proper input sensitivity setting will avoid this problem. Overly high input sensitivity settings result in no additional clean output but will result in poor sound quality and reduced speaker reliability.

**Please consult the input sensitivity setting information on page 14 of this book.**

### RECOMMENDED CONTINUOUS (RMS) POWER RANGE FOR ONE SUBWOOFER DRIVER:

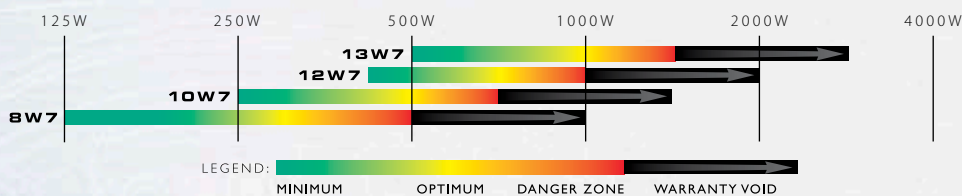

#### GREEN (MINIMUM):

From a reliability standpoint, this zone represents a very comfortable operating power range for each driver. This level of power will not stress the woofer but will not extract all of its performance potential, either.

Use of less than the minimum power level will not damage the woofer, but may result in unsatisfactory performance.

#### YELLOW (OPTIMUM):

This zone represents the best balance between long-term reliability, high output and low distortion performance. In this zone, you will be taking full advantage of the woofer's optimum, low-distortion performance range without undue risk of failure.

#### RED (MAXIMUM):

In this zone, low-distortion output and long-term reliability will be compromised (especially by an aggressive user). Slightly more SPL will be gained by pushing the power into this zone, but typically not more than 2dB, compared to the yellow zone. The closer you are to the black zone, the higher the likelihood of driver failure. Operate with caution.

#### BLACK (WARRANTY VOID):

We do not recommend operating woofers at this level of power. In this zone, there is a very high probability that the driver will fail due to excessive heat and/or mechanical stress.

**Subwoofer drivers operated at these levels of power are NOT covered under warranty.**

**When designing systems with W7 drivers, it is very important to achieve a good power match between the subwoofer amplifier and the subwoofer driver's capabilities. The power levels listed in the above chart represent continuous (RMS) amplifier power per woofer and assume that the user will regularly make full use of that power without drastically overdriving (clipping) the amplifier(s). Make sure you factor system impedance and the total number of subwoofers into your calculations. Adhering to these power recommendations will result in systems that are both reliable and enjoyable.**

# W7 Technologies

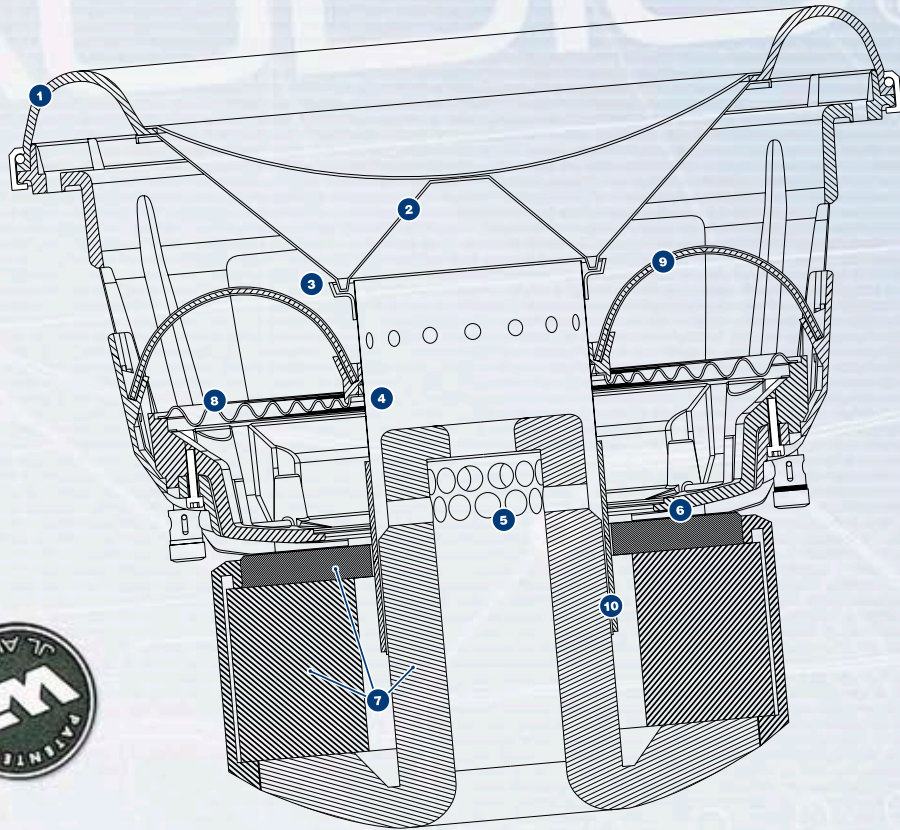

## 1 - OverRoll™ Surround (U.S. Patent #5,687,247 and #5,949,898)

By utilizing space wasted in conventional speakers, this ground-breaking innovation controls the W7's massive excursion without sacrificing precious cone area.

## 2 - W-Cone™ (U.S. Patent #6,496,590)

The W-Cone™ is a unit-body cone assembly that delivers astonishing cone stiffness with minimal mass. The shape also provides incredible torsional rigidity, which is critical to maintaining voice coil alignment at the suspension limits.

## 3 - Floating-Cone™ Attach Method (U.S. Patent #6,501,844)

Our newly conceived assembly technique ensures proper surround geometry in the assembled speaker for better excursion control and dynamic voice coil alignment. A small detail that means a lot when you're pumping the cone to the excursion extremes the W7 is capable of.

## 4 - Plateau-Reinforced Spider Attachment (U.S. Patent #6,118,884)

A derivative of JL Audio's famous VRC technology, this bulletproof suspension attachment relieves stress from the spider material at high-excursions for enhanced reliability.

## 5 - Radially Cross-Drilled Pole Piece (U.S. Patent #6,243,479)

This innovative venting system greatly enhances thermal dissipation and power handling by directing air flow onto the voice coil former, working in conjunction with technology #6.

## 6 - Massive Forced-Air-Cooled Aluminum Alloy Frame (U.S. Patent #D472,891, #6,219,431 and #6,229,902)

The elevated frame design of the W7 delivers cool air through slots directly above the top-plate to the voice coil of the speaker. This not only enhances power handling, but also sound quality by minimizing dynamic parameter shifts and power compression.

## 7 - Highly Linear, DMA-Optimized Motor System

DMA is JL Audio's proprietary Dynamic Motor Analysis system and is aimed at improving dynamic motor behavior. As a result of DMA optimization, W7 motors remain linear in motor force over an extreme range of excursion and also maintain a highly stable fixed magnetic field in the gap over a wide power range. This leads to vastly reduced distortion and faithfully reproduced transients... or put simply: tight, clean, articulate bass.

## 8 - Huge Diameter, Progressive-Roll Spider

Arrived at after intense computer analysis and optimization, the W7 spiders provide precise control and motor/voice coil alignment without prematurely limiting excursion.

## 9 - Co-Extruded Double Lead-Wires

The extruded casing and carefully engineered attachments ensure controlled lead-wire behavior under the most extreme excursion demands. Two conductors are used per connection for ample current carrying capability.

## 10 - Ultra-Long Voice Coil

To allow extreme linear excursion, phenomenal power handling and control, control, control.

In addition to the patented technologies listed above, multiple U.S. and International patents are currently pending.

**WARNING:** Prolonged exposure to high sound pressure levels can lead to permanent hearing loss. W7 subwoofers are capable of reproducing sound at extremely high sound pressure levels. Please exercise restraint in the operation of your system in order to preserve your hearing and your long-term enjoyment of this product's sound quality capabilities.

# W7 Mounting Guide

Please review the mounting procedures thoroughly before attempting to remove the speaker from its shipping baffle. The W7 mounts like no other speaker and care must be taken to follow these instructions **precisely**.



1

### Step 1: Your Tools

When you remove the W7 from its shipping carton, it is attached to an MDF baffle board. Make sure you keep this baffle board and all the packing material in the unlikely event that the W7 ever needs to be shipped back to JL Audio for service.

Two tools are required to install a W7: a large flat blade screwdriver and an electric screwdriver with a #2 Phillips-head bit.

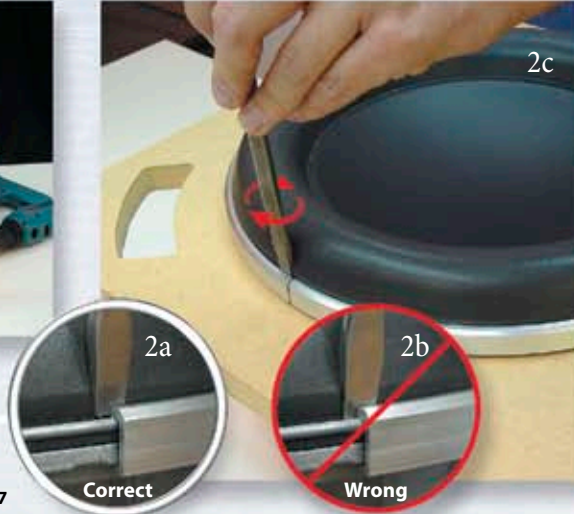

### Step 2: Remove Clamp-Ring

Gently insert the tip of the large flat-head screwdriver between the shiny aluminum clamp-ring and the foam surround (picture 2a). Be careful not to push the screwdriver too far down or it will wedge behind the hidden O-Ring (picture 2b). Gently twist the screwdriver to "pop" the clamp-ring off of the O-Ring and frame (picture 2c). This should require little effort... if you are encountering high resistance, pull the screwdriver up a bit to make sure it is not wedged behind the O-Ring. Once you have released the tip of the clamp-ring, a gentle push with your thumb in the direction of the speaker circumference (picture 2d) will separate the clamp-ring fully (picture 2f). Do **not** pull up on the ring until it is completely removed (picture 2g).



3a

### Step 3: Remove O-Ring

Once the clamp-ring is removed, the steel O-Ring is exposed. Gently lift this O-Ring up and off the speaker with your fingertips and set it aside.



3b



### Step 4: Remove Screws

Once the O-Ring is out of the way, the surround is completely free of the speaker frame (no glue is used to secure it). Lift the surround up and fold it back inside the speaker frame (picture 4a). This exposes the mounting screws (picture 4b). The surround should be folded back and in towards the center of the speaker (picture 4c). Do **not** pull it up (picture 4d) or invert it (picture 4e). While holding the surround back with two fingers as shown, back the first screw out using your electric screwdriver (picture 4f, 4g). Repeat this process eleven more times (there are twelve screws on a W7) until you have separated the speaker from the shipping baffle-board. Before you panic, be aware that the surround and cone materials are rugged and will not be damaged if you follow the procedures shown. Only careless acts like picking the speaker up by the surround or creasing it by force will cause permanent damage.

### Step 5: Ready to Install

You are now ready to install the W7 into its enclosure. The parts are shown below.



5

### Step 6: Connect the speaker wires and place the W7 into the enclosure

Connect the positive wire to the red terminal and the negative wire to the black terminal of the W7 (picture 6a). The 13W7 (not shown) has dual voice coils and must be wired with its coils in series or in parallel. Once the speaker is wired, gently lower it into the enclosure (picture 6b). This is difficult on a vertical mounting surface (because of the speaker's weight) so you should enlist the help of a second person. If you need a better grip (or are afraid of smashing your fingers) you can grasp the inside of the speaker's mounting flange (remember, the surround moves out of the way). This tip is particularly useful with the 13W7.

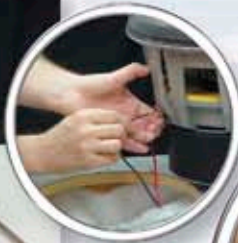

6a



6b

### Step 7: Screw it in (12 times)

Line up the screw holes of the frame with the holes that you have pre-drilled in your enclosure (you did pre-drill the holes, right?). The W7 should be attached with heavy screws such as the ones supplied with the speaker. This will necessitate pre-drilling. The use of inferior hardware (i.e. drywall screws) may lead to disastrous consequences, so don't do it. While holding the surround back with two fingers (picture 7a), screw the speaker into the enclosure (picture 7b). Once all twelve screws are in place (you did use all twelve, right?), place the surround back over the outside of the speaker frame (picture 7c).



7a



7b



7c

8a



### Step 8: Attach O-Ring

Next, take the steel O-Ring that you removed in step 3, and place it over the outside of the surround. Push it down evenly (do not seat one side first) to make sure it seats the lower lip of the surround down to the frame (pictures 8a, 8b).



8b



9a



"click"

9b



9c



9d



9e

9f

**IMPORTANT** Be sure that the beveled edge of the clamp-ring is "pointing" towards the front of the speaker. The clamp-ring is only designed to work in this orientation.

### Step 9: Attach Clamp-Ring

Place the seam of the clamp-ring where it will be least visible in the installation (usually at the bottom of the speaker). Start one end of the clamp-ring by pressing it in firmly (pictures 9a, 9b). Then work your way around from that point around the speaker, pushing the clamp-ring inward and in the direction of the circumference of the frame (pictures 9c, 9d). If you have achieved a tight fit all around, the seam will be small when you reach the starting point again (pictures 9e, 9f). Check the entire circumference for a tight fit just to be sure.

# That's it!

## You've just installed a W7!



# 13W7-D1.5

- Free Air Resonance (Fs):** 23.5 Hz
- Electrical "Q" (Qes):** 0.476
- Mechanical "Q" (Qms):** 7.517
- Total Speaker "Q" (Qts):** 0.448
- Equivalent Compliance (Vas):** 3.68 cu. ft. (104.3 ltrs)
- One-Way, Linear Excursion (Xmax)\*:** 1.25 in. (32 mm)
- Thermal Power Handling (Pt):** 1500 Watts Continuous
- Reference Efficiency (no):** 0.269 %
- Efficiency (SPL @ 1W/1m):** 86.3 dB
- DC Resistance (Re):** 2.41Ω
- Effective Piston Area (Sd):** 107.35 sq. in. (0.0693 sq. m)
- Nominal Impedance (Znom):** Dual 1.5Ω

\* Xmax specifications are derived via one-way voice coil overhang method with no correction factors applied.  
 \*\* For parallel-wired voice coils, divide "Re" by 4.  
 All other specifications remain the same.



## RECOMMENDED CONTINUOUS (RMS) POWER RANGE FOR ONE SUBWOOFER DRIVER:



## Amplifier Recommendation: 1000/1v2

**JL Audio 1000/1v2:**  
 These settings are intended as a "baseline" for tuning your system. Depending on your vehicle and your preferences, some variation in the crossover and bass control settings may be necessary for optimum performance.

### Bass EQ:

Generally not necessary in W7 applications (we recommend defeating it by switching the "Bass EQ" switch to "Off"). May be used with Remote Bass Control to provide some user controllable broad bass boost. When used in this manner, set "Q" to "1.1", set "Center Freq." to "45" Hz, "Boost" is defeated by connection of Remote Bass Control.

**Infrasonic Filter:**  
 Turn "Off" for Sealed Enclosure.  
 Turn "On" for Ported Enclosure and set the knob to "25" Hz.

### Input Sensitivity Controls:

*Proper adjustment of these controls is critical!*  
 For virtually all aftermarket head units, set "Input Voltage" to "Low". See "Input Sensitivity Setting Guide" on pg. 14 for precise setting instructions.

### Dual Mono Speaker Output Connections:

Connect wire directly to "+" and "-" "Subwoofer Output" connections and to the W7.

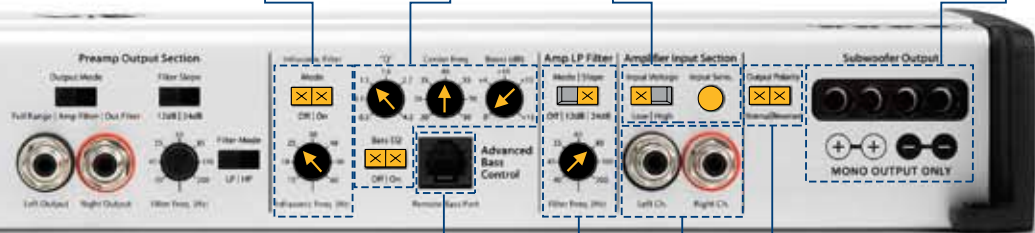

**Remote Bass Port:**  
 Permits connection of an optional remote bass boost controller (RBC-1), giving you control over the boost of the parametric EQ from the front of the vehicle. The RBC-1 controller is sold separately.

**Amp Low-Pass Filter:**  
 Set "Mode/Slope" switch to "24dB". Set "Filter Freq. (Hz)" knob to "85". Lower settings are likely to result in a poor transition between the upper response of the W7 and the lower response of the mid-bass speakers.

**Amplifier Input:**  
 Connect RCA-type cables from the head unit (or processor) to these two jacks. Use both jacks (with a Y-adaptor if necessary).

**Output Polarity:**  
 Carefully listen to the sub-bass to mid-bass transition with music that has strong mid-bass content. Select the switch position which gives the smoothest, most natural mid-bass response. If using multiple 1000/1's on multiple subwoofers, make sure this switch is set to the same position on all amplifiers.

- = position of knob
- = position of switch
- = switch with two possible positions
- = setting will vary (see sidebar)

# Driver Specifications

**Grille Clearance:** 2.7 in. (69 mm) from the bottom of the mounting flange to the lowest inside surface of the grille.

**Displacement:** 0.21 cu. ft. (5.9 ltrs)

**Net Weight:** 52 lbs. (23.6 kg)

**Mounting Hardware:** Twelve #12 x 1.75" long clear, zinc-plated steel Phillips pan-head sheet metal screws (included) **or** twelve #12-28 long steel Phillips pan-head machine screws with #12-28 T-Nuts, each at least 1/2-inch (12.5 mm) longer than the thickness of the mounting baffle (not included).

**Unpacking/Mounting:** Please refer to the "How to: Mount a W7 Subwoofer" on pages 4 & 5 for detailed, step-by-step instructions.

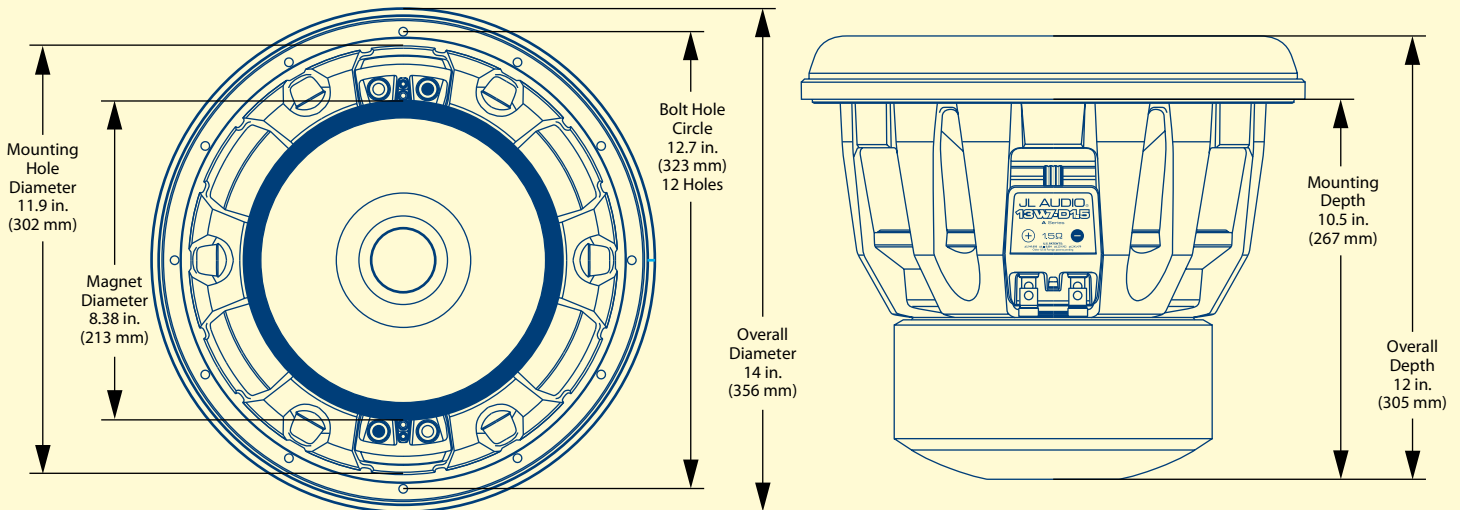

# Enclosure Specifications

Net volumes given below do not include the air volume displaced by the speaker (Driver Displacement). This value must be added to the net volume along with the displacement of any braces and/or ports (if applicable) to arrive at a gross internal volume. Air inside a port is not part of the effective net volume. Calculate ports as solid, not hollow objects.

The dimensions given for the enclosure examples below take all applicable displacements into consideration.

### SAFETY NOTICE!

It is absolutely essential that the completed subwoofer enclosure is mounted firmly to the vehicle with heavy steel bolts (1/2 inch diameter) and large steel washers on both sides of the bolts. This will reduce the likelihood of occupant injury in the event of a collision or sudden deceleration.

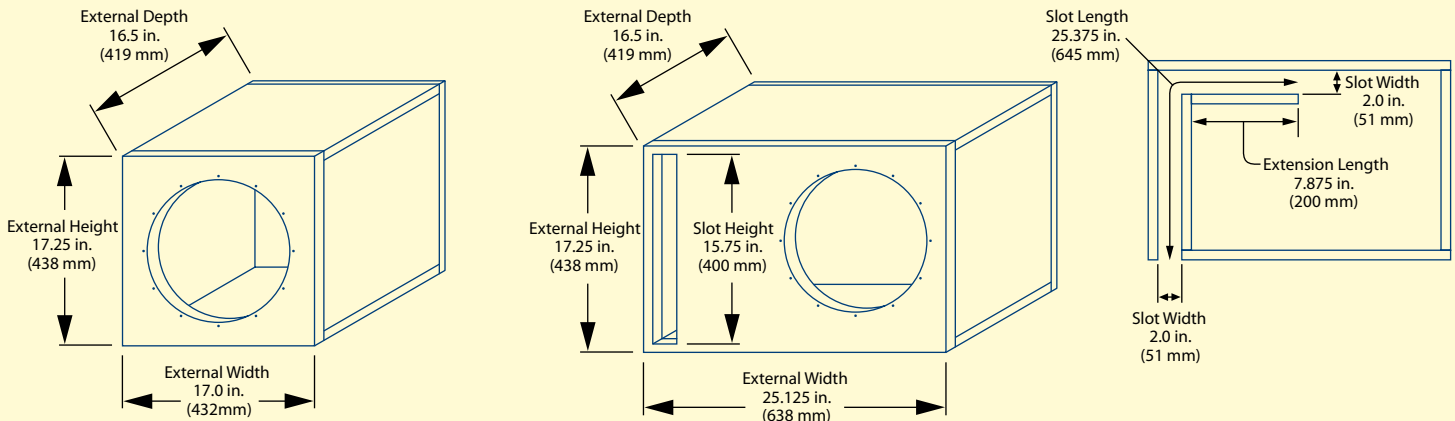

### SEALED ENCLOSURE:

**Recommended Net Volume:** 1.875 cu. ft. (53.1 ltrs.)

**Fc:** 40.8 Hz **F3:** 36.3 Hz **Qtc:** 0.806

**Front Baffle Thickness:** 1 in. (25 mm)

**Wall Thickness:** 0.75 in. (19 mm)

### PORTED ENCLOSURE:

**Recommended Net Volume:** 2.375 cu. ft. (67.3 ltrs.)

**Recommended Port Tuning:** 30 Hz

**Port Type:** "Slot" ports are recommended. See information above. The port recommendations listed above are derived through actual tests and measurements (not computer simulations).

**Front Baffle Thickness:** 1 in. (25 mm)

**Wall Thickness:** 0.75 in. (19 mm)

# 12W7-3



**Free Air Resonance (Fs):** 27.2 Hz  
**Electrical "Q" (Qes):** 0.514  
**Mechanical "Q" (Qms):** 7.807  
**Total Speaker "Q" (Qts):** 0.482  
**Equivalent Compliance (Vas):** 2.33 cu. ft. (66.0 ltrs)  
**One-Way, Linear Excursion (Xmax)\*:** 1.15 in. (29 mm)  
**Thermal Power Handling (Pt):** 1000 Watts Continuous  
**Reference Efficiency (no):** 0.249 %  
**Efficiency (SPL @ 1W/1m):** 86.2 dB  
**DC Resistance (Re):** 2.47Ω  
**Effective Piston Area (Sd):** 84 sq. in. (0.0542 sq. m)  
**Nominal Impedance (Znom):** 3Ω

\*Xmax specifications are derived via one-way voice coil overhang method with no correction factors applied.



## RECOMMENDED CONTINUOUS (RMS) POWER RANGE FOR ONE SUBWOOFER DRIVER:



## Amplifier Recommendation: 1000/1v2 (pictured), HD750/1, 500/1v2 or G-MAX

### JL Audio 1000/1v2:

These settings are intended as a "baseline" for tuning your system. Depending on your vehicle and your preferences, some variation in the crossover and bass control settings may be necessary for optimum performance. (See settings on page 10 for 500/1.)

### Bass EQ:

Generally not necessary in W7 applications (we recommend defeating it by switching the "Bass EQ" switch to "Off"). May be used with Remote Bass Control to provide some user controllable broad bass boost. When used in this manner, set "Q" to "1.1", set "Center Freq." to "45" Hz, "Boost" is defeated by connection of Remote Bass Control.

### Infrasonic Filter:

Turn "Off" for Sealed Enclosure. Turn "On" for Ported Enclosure and set the knob to "25" Hz.

### Input Sensitivity Controls:

Proper adjustment of these controls is critical!

For virtually all aftermarket head units, set "Input Voltage" to "Low". See "Input Sensitivity Setting Guide" on pg. 14 for precise setting instructions.

### Dual Mono Speaker Output Connections:

Connect wire directly to "+" and "-" "Subwoofer Output" connections and to the W7.

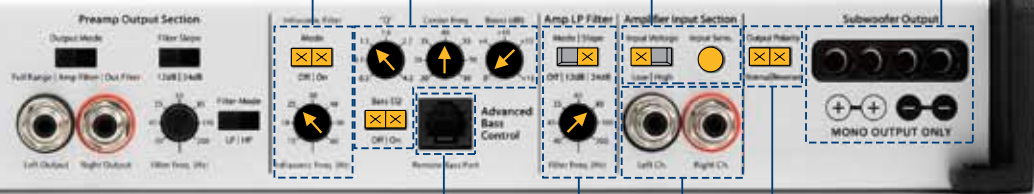

### Remote Bass Port:

Permits connection of an optional remote bass boost controller (RBC-1), giving you control over the boost of the parametric EQ from the front of the vehicle. The RBC-1 controller is sold separately.

### Amp Low-Pass Filter:

Set "Mode/Slope" switch to "24dB". Set "Filter Freq. (Hz)" knob to "85". Lower settings are likely to result in a poor transition between the upper response of the W7 and the lower response of the mid-bass speakers.

### Amplifier Input:

Connect RCA-type cables from the head unit (or processor) to these two jacks. Use both jacks (with a Y-adaptor if necessary).

### Output Polarity:

Carefully listen to the sub-bass to mid-bass transition with music that has strong mid-bass content. Select the switch position which gives the smoothest, most natural mid-bass response. If using multiple 1000/1's on multiple subwoofers, make sure this switch is set to the same position on all amplifiers.

- = position of knob
- = position of switch
- = switch with two possible positions
- = setting will vary (see sidebar)



# Driver Specifications

**Grille Clearance:** 2.6 in. (66 mm) from the bottom of the mounting flange to the lowest inside surface of the grille.

**Displacement:** 0.14 cu. ft. (4.0 ltrs)

**Net Weight:** 45 lbs. (20.4 kg)

**Mounting Hardware:** Twelve #10 x 1.75" long clear, zinc-plated steel Phillips pan-head sheet metal screws (included) **or** twelve #10-32 long steel Phillips pan-head machine screws with #10-32 T-Nuts, each at least 1/2-inch (12.5 mm) longer than the thickness of the mounting baffle (not included).

**Unpacking/Mounting:** Please refer to the "How to Mount a W7 Subwoofer" on pages 4 & 5 for detailed, step-by-step instructions.

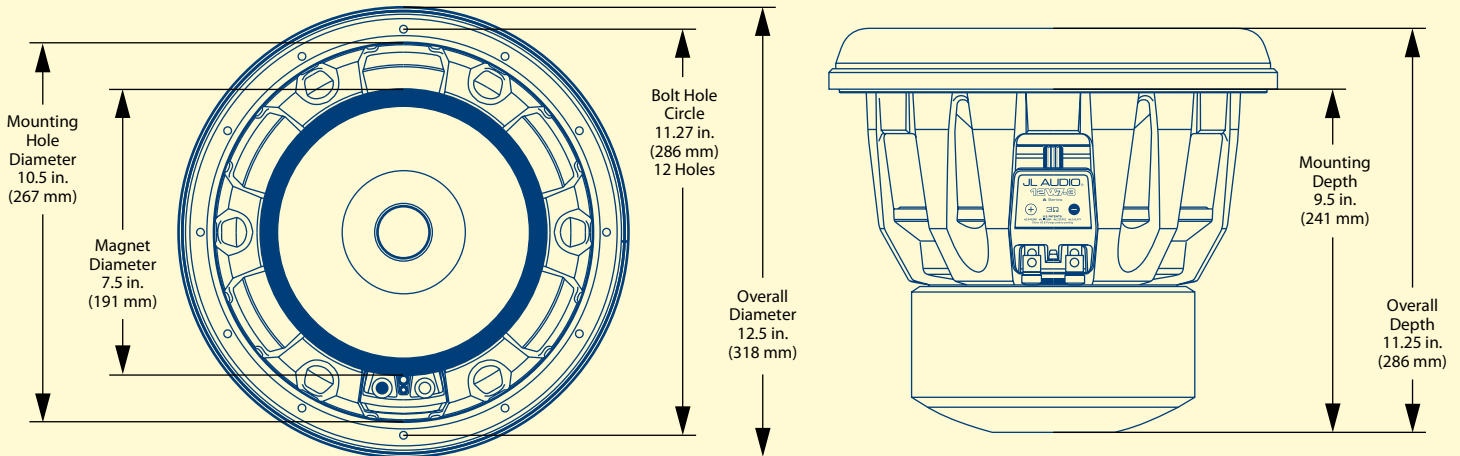

# Enclosure Specifications

Net volumes given below do not include the air volume displaced by the speaker (Driver Displacement). This value must be added to the net volume along with the displacement of any braces and/or ports (if applicable) to arrive at a gross internal volume. Air inside a port is not part of the effective net volume. Calculate ports as solid, not hollow objects.

The dimensions given for the enclosure examples below take all applicable displacements into consideration.

### SAFETY NOTICE!

It is absolutely essential that the completed subwoofer enclosure is mounted firmly to the vehicle with heavy steel bolts (1/2 inch diameter) and large steel washers on both sides of the bolts. This will reduce the likelihood of occupant injury in the event of a collision or sudden deceleration.

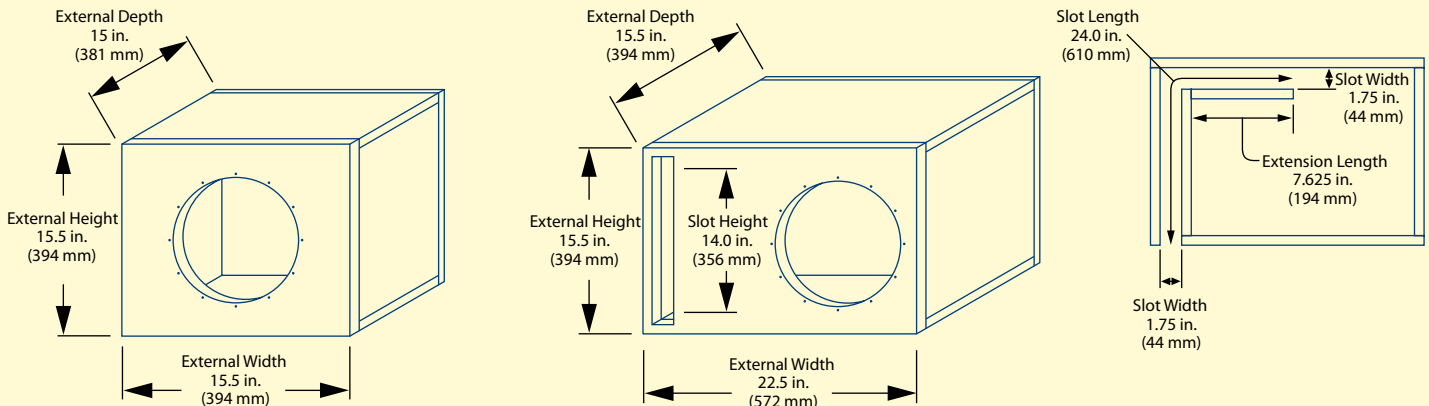

### SEALED ENCLOSURE:

**Recommended Net Volume:** 1.375 cu. ft. (38.94 ltrs.)

**Fc:** 44.7 Hz **F3:** 40.4 Hz **Qtc:** 0.792

**Front Baffle Thickness:** 1 in. (25 mm)

**Wall Thickness:** 0.75 in. (19 mm)

### PORTED ENCLOSURE:

**Recommended Net Volume:** 1.75 cu. ft. (51.54 ltrs.)

**Recommended Port Tuning:** 32 Hz

**Port Type:** "Slot" ports are recommended. See information above. The port recommendations listed above are derived through actual tests and measurements (not computer simulations).

**Front Baffle Thickness:** 1 in. (25 mm)

**Wall Thickness:** 0.75 in. (19 mm)



# 10W7-3

- Free Air Resonance (Fs):** 30.6 Hz
- Electrical "Q" (Qes):** 0.578
- Mechanical "Q" (Qms):** 7.647
- Total Speaker "Q" (Qts):** 0.537
- Equivalent Compliance (Vas):** 1.28 cu. ft. (36.1 ltrs)
- One-Way, Linear Excursion (Xmax)\*:** 0.9 in. (23 mm)
- Thermal Power Handling (Pt):** 750 Watts Continuous
- Reference Efficiency (no):** 0.171 %
- Efficiency (SPL @ 1W/1m):** 84.3 dB
- DC Resistance (Re):** 2.75Ω
- Effective Piston Area (Sd):** 59.8 sq. in. (0.0386 sq. m)
- Nominal Impedance (Znom):** 3Ω

\*Xmax specifications are derived via one-way voice coil overhang method with no correction factors applied.



## RECOMMENDED CONTINUOUS (RMS) POWER RANGE FOR ONE SUBWOOFER DRIVER:



## Amplifier Recommendation: 500/1v2 (pictured), HD750/1 or G-MAX

### JL Audio 500/1v2:

These settings are intended as a "baseline" for tuning your system. Depending on your vehicle and your preferences, some variation in the crossover and bass control settings may be necessary for optimum performance.

### Bass EQ:

Generally not necessary in W7 applications (we recommend defeating it by switching the "Bass EQ" switch to "Off"). May be used with Remote Bass Control to provide some user controllable broad bass boost. When used in this manner, set "Q" to "1.1", set "Center Freq." to "45" Hz, "Boost" is defeated by connection of Remote Bass Control.

### Infrasonic Filter:

Turn "Off" for Sealed Enclosure. Turn "On" for Ported Enclosure and set the knob to "25" Hz.

### Input Sensitivity Controls:

Proper adjustment of these controls is critical! For virtually all aftermarket head units, set "Input Voltage" to "Low". See "Input Sensitivity Setting Guide" on pg. 14 for precise setting instructions.

### Dual Mono Speaker Output Connections:

Connect wire directly to "+" and "-" "Subwoofer Output" connections and to the W7.

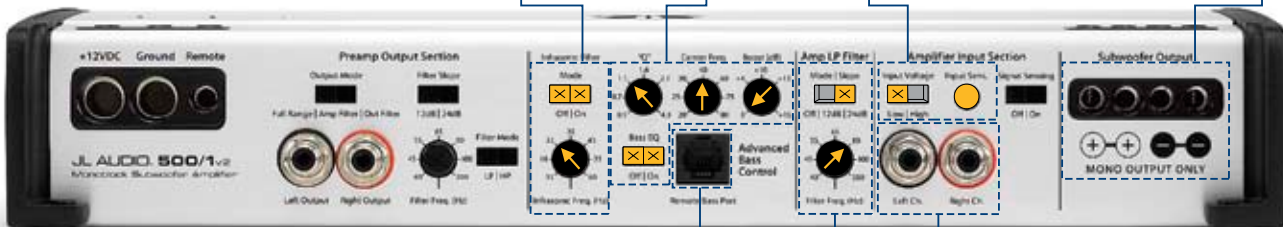

### Remote Bass Port:

Permits connection of an optional remote bass boost controller (RBC-1), giving you control over the boost of the parametric EQ from the front of the vehicle. The RBC-1 controller is sold separately.

### Amp Low-Pass Filter:

Set "Mode/Slope" switch to "24dB". Set "Filter Freq. (Hz)" knob to "85". Lower settings are likely to result in a poor transition between the upper response of the W7 and the lower response of the mid-bass speakers.

### Amplifier Input:

Connect RCA-type cables from the head unit (or processor) to these two jacks. Use both jacks (with a Y-adaptor if necessary).

- = position of knob
- = position of switch
- = switch with two possible positions
- = setting will vary (see sidebar)

# Driver Specifications

**Grille Clearance:** 2.25 in. (57 mm) from the bottom of the mounting flange to the lowest inside surface of the grille.

**Displacement:** 0.09 cu. ft. (2.5 ltrs)

**Net Weight:** 30 lbs. (15.8 kg)

**Mounting Hardware:** Twelve #10 x 1.75" long clear, zinc-plated steel Phillips pan-head sheet metal screws (included) **or** twelve #10-32 long steel Phillips pan-head machine screws with #10-32 T-Nuts, each at least 1/2-inch (12.5 mm) longer than the thickness of the mounting baffle (not included).

**Unpacking/Mounting:** Please refer to the "How to: Mount a W7 Subwoofer" on pages 4 & 5 for detailed, step-by-step instructions.

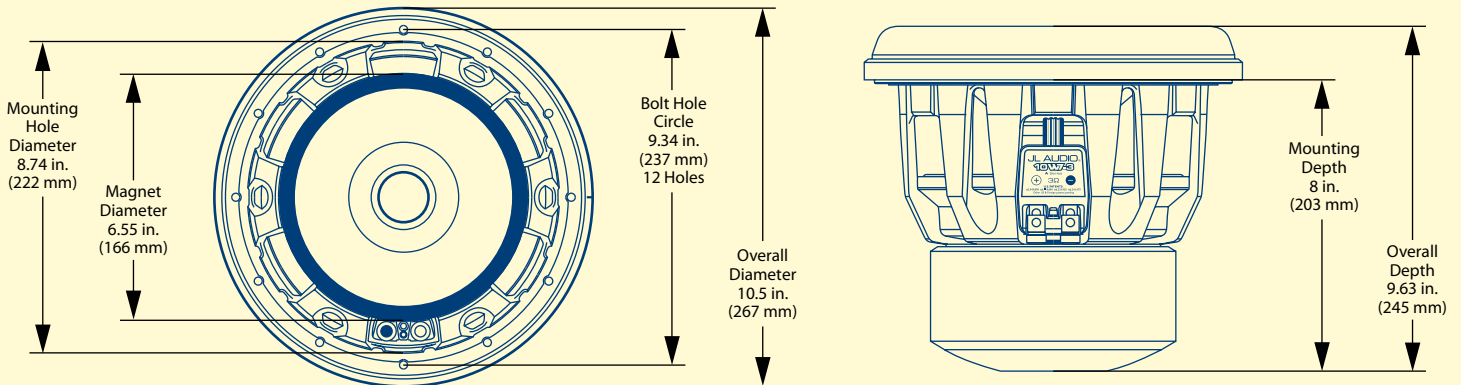

# Enclosure Specifications

Net volumes given below do not include the air volume displaced by the speaker (Driver Displacement). This value must be added to the net volume along with the displacement of any braces and/or ports (if applicable) to arrive at a gross internal volume. Air inside a port is not part of the effective net volume. Calculate ports as solid, not hollow objects.

The dimensions given for the enclosure examples below take all applicable displacements into consideration.

### SAFETY NOTICE!

It is absolutely essential that the completed subwoofer enclosure is mounted firmly to the vehicle with heavy steel bolts (1/2 inch diameter) and large steel washers on both sides of the bolts. This will reduce the likelihood of occupant injury in the event of a collision or sudden deceleration.

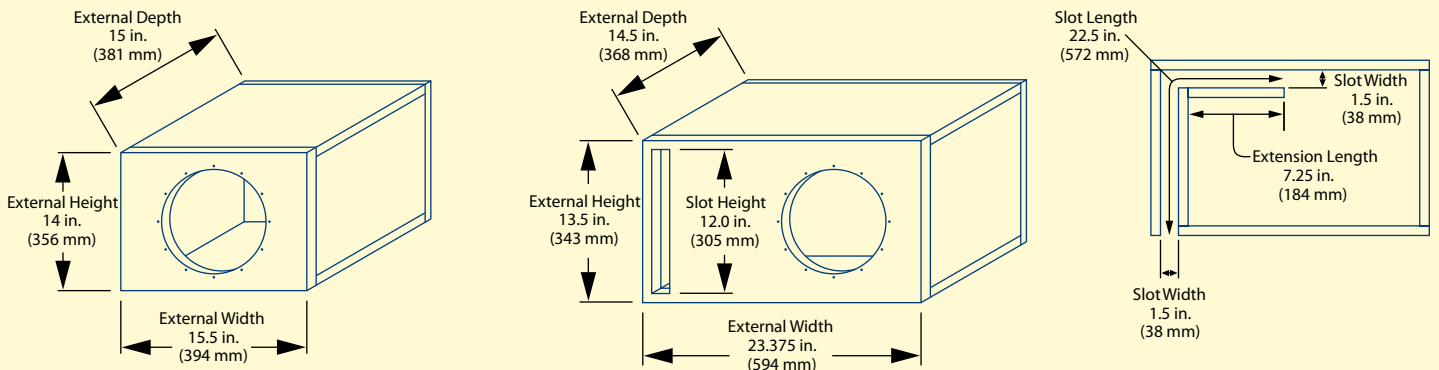

### SEALED ENCLOSURE:

**Recommended Net Volume:** 1.25 cu. ft. (35.4 ltrs.)

**Fc:** 44.7 Hz **F3:** 40.7 Hz **Qtc:** 0.785

**Front Baffle Thickness:** 1 in. (25 mm)

**Wall Thickness:** 0.75 in. (19 mm)

### PORTED ENCLOSURE:

**Recommended Net Volume:** 1.5 cu. ft. (42.5 ltrs.)

**Recommended Port Tuning:** 32 Hz

**Port Type:** "Slot" ports are recommended. See information above. The port recommendations listed above are derived through actual tests and measurements (not computer simulations).

**Front Baffle Thickness:** 1 in. (25 mm)

**Wall Thickness:** 0.75 in. (19 mm)

# 8W7-3



**Free Air Resonance (Fs):** 35.2 Hz  
**Electrical "Q" (Qes):** 0.654  
**Mechanical "Q" (Qms):** 9.50  
**Total Speaker "Q" (Qts):** 0.612  
**Equivalent Compliance (Vas):** 0.61 cu. ft. (17.4 ltrs)  
**One-Way, Linear Excursion (Xmax)\*:** 0.75 in. (19 mm)  
**Thermal Power Handling (Pt):** 500 Watts Continuous  
**Reference Efficiency (no):** 0.112 %  
**Efficiency (SPL @ 1W/1m):** 82.7 dB  
**DC Resistance (Re):** 2.78Ω  
**Effective Piston Area (Sd):** 38.0 sq. in. (0.0245 sq. m)  
**Nominal Impedance (Znom):** 3Ω

\* Xmax specifications are derived via one-way voice coil overhang method with no correction factors applied.



## RECOMMENDED CONTINUOUS (RMS) POWER RANGE FOR ONE SUBWOOFER DRIVER:



## Amplifier Recommendation: 250/1v2 (pictured) or G1700

**JL Audio 250/1v2:**  
 These settings are intended as a "baseline" for tuning your system. Depending on your vehicle and your preferences, some variation in the crossover and bass control settings may be necessary for optimum performance.

**Input Sensitivity Controls:**  
*Proper adjustment of these controls is critical!*  
 For virtually all aftermarket head units, set "Input Voltage" to "Low". See "Input Sensitivity Setting Guide" on pg. 14 for precise setting instructions.

**Dual Mono Speaker Output Connections:**  
 Connect wire directly to "+" and "-" "Subwoofer Output" connections and to the W7.

**Infrasonic Filter:**  
 Switch "Off" for Sealed Enclosure. Switch to "30Hz" for Ported Enclosure

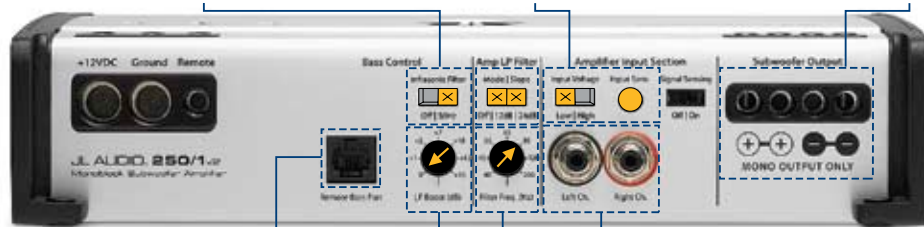

**Remote Bass Port:**  
 Permits connection of an optional remote bass boost controller (RBC-1), giving you control over the EQ boost from the front of the vehicle. The RBC-1 controller is sold separately.

**LF Boost:**  
 Generally not necessary in W7 applications (we recommend defeating it by turning the dial to "0").

**Amp Low-Pass Filter:**  
 Set "Mode/Slope" switch to "24dB". Set "Filter Freq. (Hz)" knob to "85". Lower settings are likely to result in a poor transition between the upper response of the W7 and the lower response of the mid-bass speakers.

**Amplifier Input:**  
 Connect RCA-type cables from the head unit (or processor) to these two jacks. Use both jacks (with a Y-adaptor if necessary).

- = position of knob
- = position of switch
- = switch with two possible positions
- = setting will vary (see sidebar)

# Driver Specifications

**Grille Clearance:** 2.3125 in. (25 mm) from the bottom of the mounting flange to the lowest inside surface of the grille.

**Displacement:** 0.06 cu. ft. (1.7 ltrs)

**Net Weight:** 17 lbs. (7.8 kg)

**Mounting Hardware:** Twelve #8 x 1.00" long clear, zinc-plated steel Phillips pan-head sheet metal screws (included) **or** twelve #8-32 long steel Phillips pan-head machine screws with #8-32 T-Nuts, each at least 1/2-inch (12.5 mm) longer than the thickness of the mounting baffle (not included).

**Unpacking/Mounting:** Please refer to the "W7 Installation: Mounting System" sheet for detailed, step-by-step instructions.

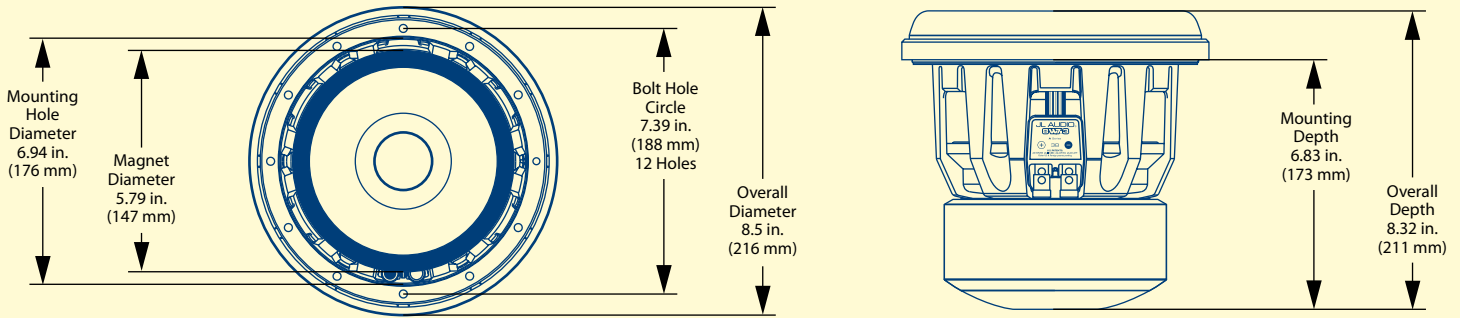

# Enclosure Specifications

Net volumes given below do not include the air volume displaced by the speaker (Driver Displacement). This value must be added to the net volume along with the displacement of any braces and/or ports (if applicable) to arrive at a gross internal volume. Air inside a port is not part of the effective net volume. Calculate ports as solid, not hollow objects.

The dimensions given for the enclosure examples below take all applicable displacements into consideration.

### SAFETY NOTICE!

It is absolutely essential that the completed subwoofer enclosure is mounted firmly to the vehicle with heavy steel bolts (1/2 inch diameter) and large steel washers on both sides of the bolts. This will reduce the likelihood of occupant injury in the event of a collision or sudden deceleration.

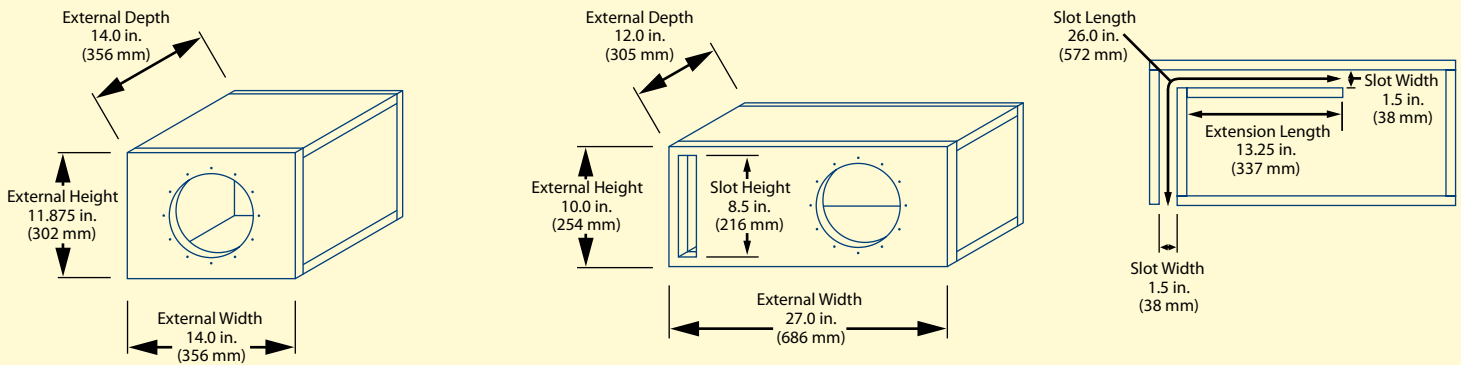

### SEALED ENCLOSURE:

**Recommended Net Volume:** 0.875 cu. ft. (24.8 ltrs.)

**Fc:** 46.0 Hz **F3:** 41.3 Hz **Qtc:** 0.797

**Front Baffle Thickness:** 0.75 in. (19 mm)

**Wall Thickness:** 0.75 in. (19 mm)

### PORTED ENCLOSURE:

**Recommended Net Volume:** 1.0 cu. ft. (28.3 ltrs.)

**Recommended Port Tuning:** 32 Hz

**Port Type:** "Slot" ports are recommended. See information above.

The port recommendations listed above are derived through actual tests and measurements (not computer simulations).

**Front Baffle Thickness:** 0.75 in. (19 mm)

**Wall Thickness:** 0.75 in. (19 mm)

# Input Sensitivity Setting Guide

What follows is a simple method for accurately setting the input sensitivity (commonly referred to as “gain”) of JL Audio subwoofer amplifiers. You will need the following equipment:

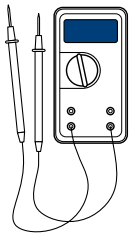

- AC Voltmeter (digital display type)
- A CD with a sine-wave test tone recorded at 0dB reference level in the frequency range to be amplified (40-50 Hz works well). Do not use attenuated test tones (-10dB, -20dB, etc.).

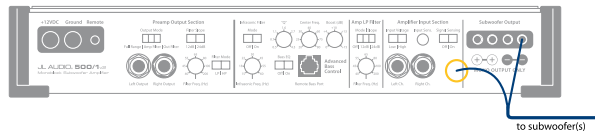
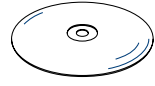

**Step 1:** Disconnect the W7(s) from the amplifier (It is only necessary to disconnect one wire).



**Step 2:** Turn “Off” all processing on the head unit and amplifier (bass / treble, loudness, EQ, etc.)

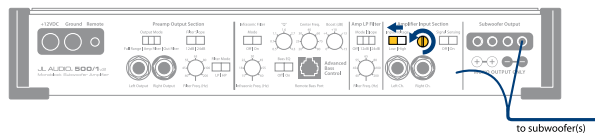

**Step 3:** Switch “Input Voltage” to “Low” and turn the “Input Sensitivity” control on the amplifier all the way down (full counter-clockwise).

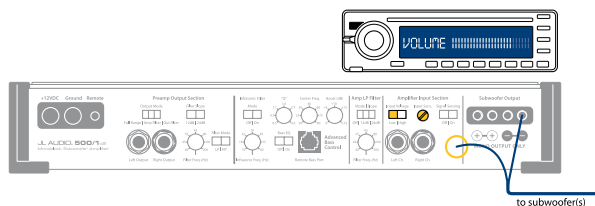

**Step 4:** Verify that you have disconnected the subwoofers from the amplifier. Then, set the head unit’s volume to 3/4 of full volume.



**Step 5:** Play a test track with a sine-wave (pure tone) between 40-50 Hz.

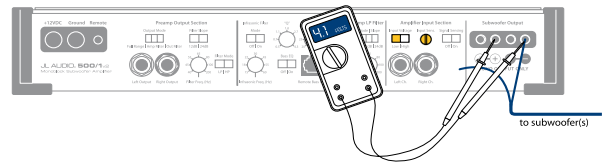

**Step 6:** Connect the AC voltmeter to the “Subwoofer Output” of the amplifier.

**Step 7:** Consult “Appendix A” in your JL Audio amplifier’s Owner’s Manual and find the correct target output voltage for that model and the nominal impedance of your W7 subwoofer setup.

**If you are using another brand of amplifier, we recommend that you use an oscilloscope to verify the maximum unclipped output in the vehicle at realistic vehicle supply voltages.**

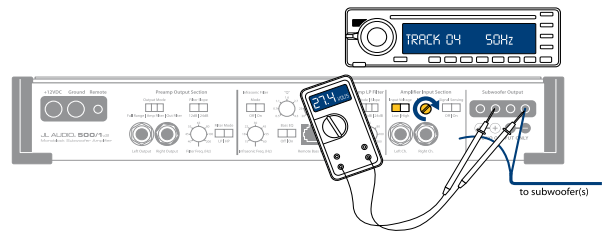

**Step 8:** Increase the “Input Sensitivity” control (clockwise) until the listed voltage is delivered. To level-match multiple subwoofer amps, set each one to the listed voltage. If excessive voltage is read with the control at minimum (full counter-clockwise), switch the “Input Voltage” to “High” and re-adjust.

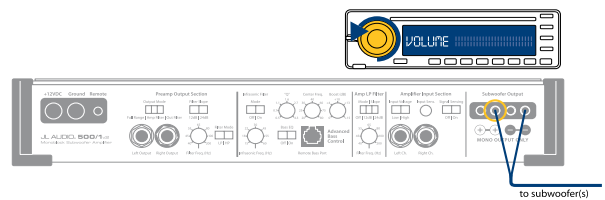

**Step 9:** Reduce the head unit’s volume and turn it off. Reconnect the subwoofers to the amplifier.



## Limited Warranty

JL AUDIO warrants this speaker to be free of defects in materials and workmanship for a period of **one (1) year** from the original date of purchase.

This warranty is not transferrable and applies only to the original purchaser of the product from an authorized JL AUDIO dealer. Should service be necessary under this warranty for any reason due to manufacturing defect or malfunction, JL AUDIO will, at its discretion, repair or replace the defective product with new or remanufactured product at no charge.

Damage caused by the following is not covered under warranty: accident, misuse, abuse, product modification or neglect, failure to follow installation instructions, unauthorized repair attempts, misrepresentations by the seller. This warranty does not cover incidental or consequential damages and does not cover the cost of removing or reinstalling the unit(s). Cosmetic damage due to accident or normal wear and tear is not covered under warranty.

Any applicable implied warranties are limited in duration to the period of the express warranty as provided herein beginning with the date of the original purchase at retail, and no warranties, whether express or implied, shall apply to this product thereafter. Some states do not allow limitations on implied warranties, therefore these exclusions may not apply to you. This warranty gives you specific legal rights, and you may also have other rights which vary from state to state.

### **If you need service on your JL AUDIO product:**

All warranty returns should be sent to JL AUDIO freight prepaid through an authorized JL AUDIO dealer and must be accompanied by proof of purchase (a copy of the original sales receipt). Direct returns from consumers or non-authorized dealers will be refused unless specifically authorized by JL AUDIO with a valid return authorization number. Warranty expiration on products returned without proof of purchase will be determined from the manufacturing date code. Coverage may be invalidated as this date is previous to purchase date. Return only defective components. Non-defective items received will be returned freight-collect. The customer is responsible for shipping charges and insurance in sending the product to JL AUDIO. Freight damage on returns is not covered under warranty. Always include proof of purchase (sales receipt).

### **For Service Information in the U.S.A. please call:**

JL Audio customer service: (954) 443-1100 during normal business hours (Eastern Time)

### **JL Audio, Inc**

10369 North Commerce Parkway, Miramar, FL 33025

### **International Warranties:**

Products purchased outside the United States of America are covered only by that country's distributor and not by JL Audio, Inc.



HOME AUDIO | MOBILE AUDIO | MARINE AUDIO

"JL Audio" and the JL Audio logo are registered trademarks of JL Audio, Inc. "W7", "VRC", "OverRoll", "W-Cone", "Ahead of the Curve", and their respective logos are trademarks of JL Audio, Inc.

SKU#011171 • JLA-02-2008 • Printed in USA • ©2008 JL Audio, Inc.  
U.S. PATENTS: #5,734,734 #5,949,898 #6,118,884 #6,229,902  
#6,243,479 #6,294,959 #6,501,844 #6,496,590 #6,441,685  
#5,687,247 #6,219,431 #6,625,292 #D472,891 #D480,709 Other  
U.S. & Foreign patents pending. For more detailed information  
please visit us online at [www.jlaudio.com](http://www.jlaudio.com).

Due to our policy of continuous product development,  
all specifications are subject to change without notice.



[www.jlaudio.com](http://www.jlaudio.com)

10369 North Commerce Parkway • Miramar, Florida • 33025 • USA